

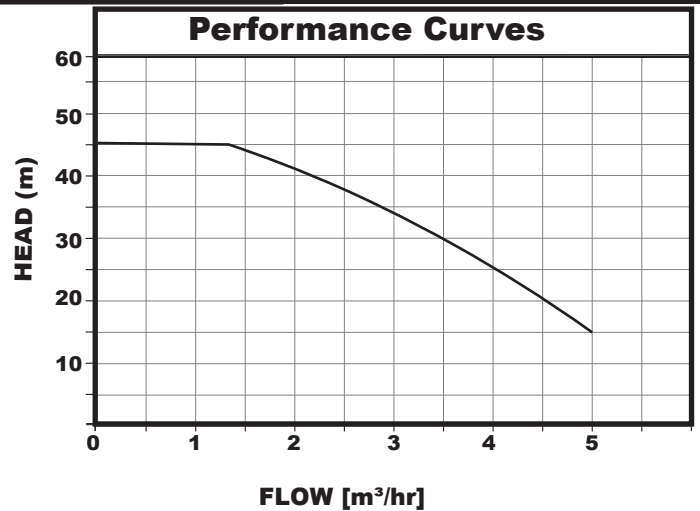

SMART 45

**CONSTANT PRESSURE
VFD
BOOSTER PUMP**



FEATURES

Constant Pressure: A total smart pump that is able to adjust performance in variable speed according to water demand and provide constant pressure.

Energy saving: The pump has a permanent magnet motor to reduce power consumption while the variable speed control matches the power consumption with the required water demand.

Easy installation: Plug and pump. Quick connector 5" adjustable all around easy to fit with piping line.

Self-priming function: Able to lift water from 8meters underground within 5minutes

Temperature of up to 80°C hot water: Able to pump hot water upto 80°C

Eco-friendly materials: All components are in accordance with the European standards of RoHS & PAHS, no pollution to water. The standards are to restrict the hazardous substances in electrical and electronic equipment and protect human and animal health and the environment

Silent design: Optimised hydraulic structure to minimize the mechanical noise, electromagnetic noise and fluid noise

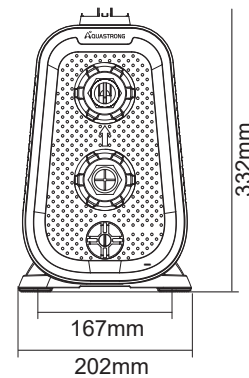
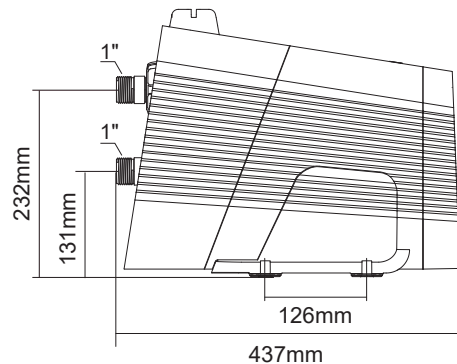

MAX.3bar

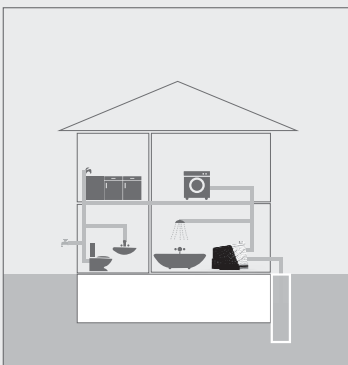

MAX.4bar

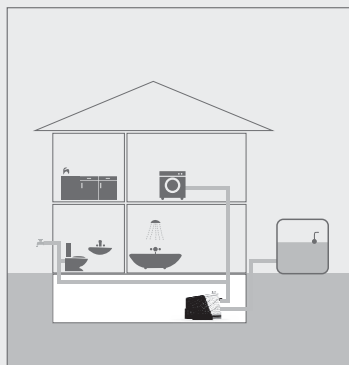

MAX.5.5bar

