

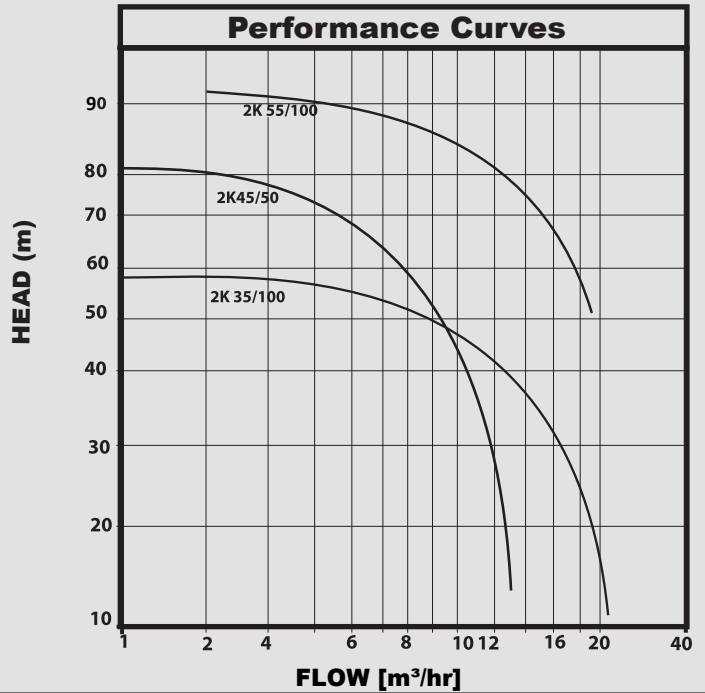

## 2K TWIN

## BOOSTER SETS



### APPLICATIONS

DAB booster sets are designed for water pressure boosting in commercial and residential buildings and are also suitable for fire hose reels.

### CONSTRUCTION FEATURES

The sets comprises of two DAB self priming jet pumps, pressure tanks, two independent pressure switches, pressure gauge, pressure control panel configured for duty/assist, all mounted on a base plate complete with galvanized manifolds and isolating valves

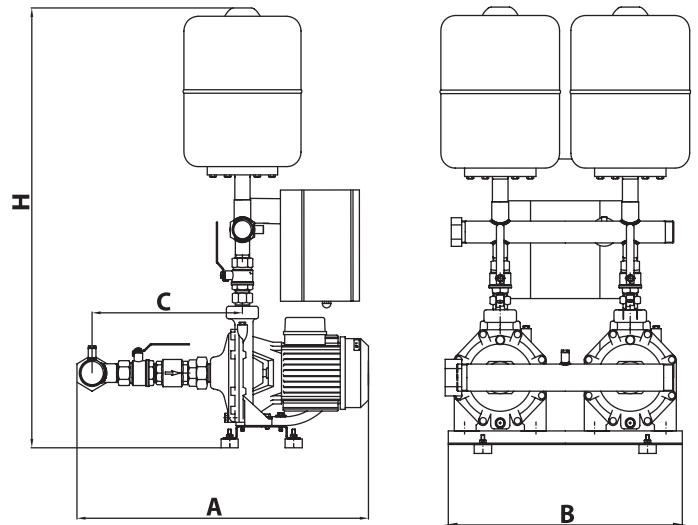

### TECHNICAL DATA

MODEL	VOLTAGE	kW	HP	Amps	A	B	H	MANIFOLD		WEIGHT KG
								SUCTION	DELIVERY	
2K 35/100M	240V	1.1	1.5	7.1	387	205	233	2"	1 1/2"	70
2K 45/50M				8.3	370	210	268			
2K 50/100T	415V	2.2	3	6.7	450	256	312			