

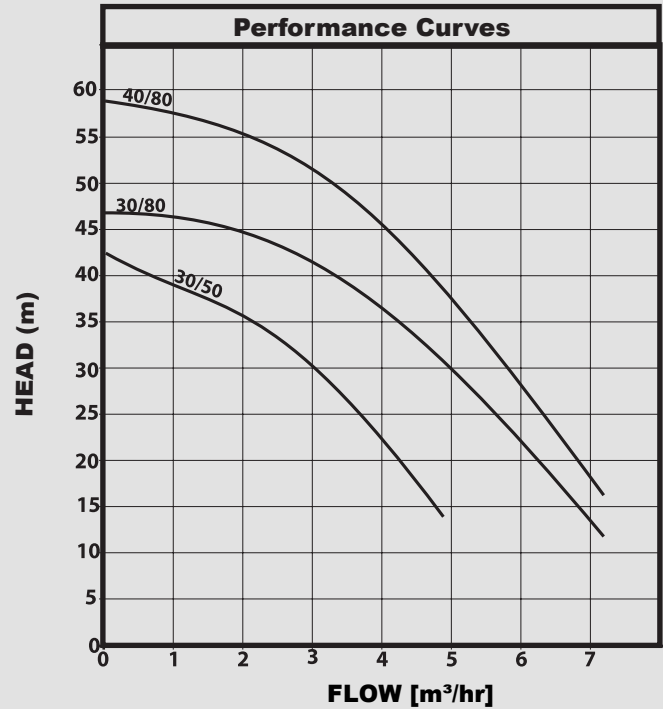

# EURO

# HORIZONTAL CENTRIFUGAL PUMPS

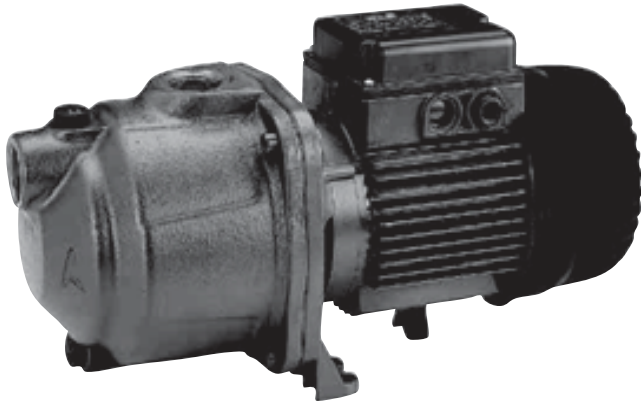

### APPLICATIONS

Multistage centrifugal pumps extremely silent used especially for supplying water to domestic installations. Also ideal for use in small-scale agriculture and gardening.

### CONSTRUCTION FEATURES

Cast iron pump body, stainless steel disc cover and pressure disc, die-cast aluminium motor support, technopolymer impeller, diffuser, venturi tube and carbon/ceramic mechanical seal.

**Motor Protection:** IP44

**Terminal Box Protection:** IP55

**Insulation Class:** F

**Liquid Quality Requirements:** Clean, free of solids or abrasive substances.

**Temperature:** 0°C to 40°C

**Maximum Suction Depth:** 8 metres at sea level

**Maximum Operating Pressure:** 8 bar

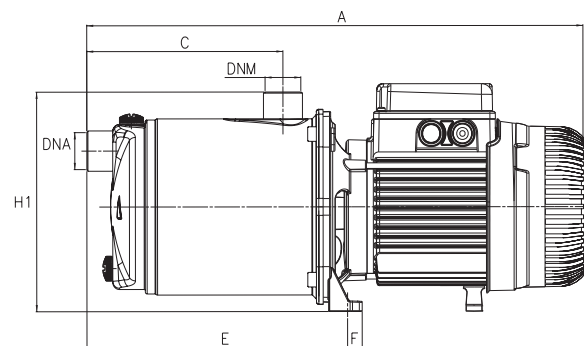
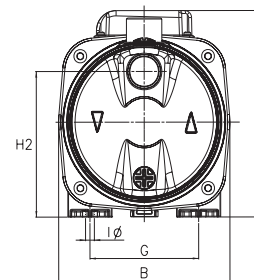

### TECHNICAL DATA

Model	Motor Type	Power [kW]	HP	Amps	A	B	C	E	F	G	H	H1	H1	DNA	Weight KG
EURO 30/50	240V	0.55	0.75	3.9	384	174	108	241	13.5	111	193	196	143	1"	10.5
EURO 30/80		0.8	1.1	5.3	458		166				203				14.6
EURO 40/80		1	1.36	6.5	458		166				203				15.1