

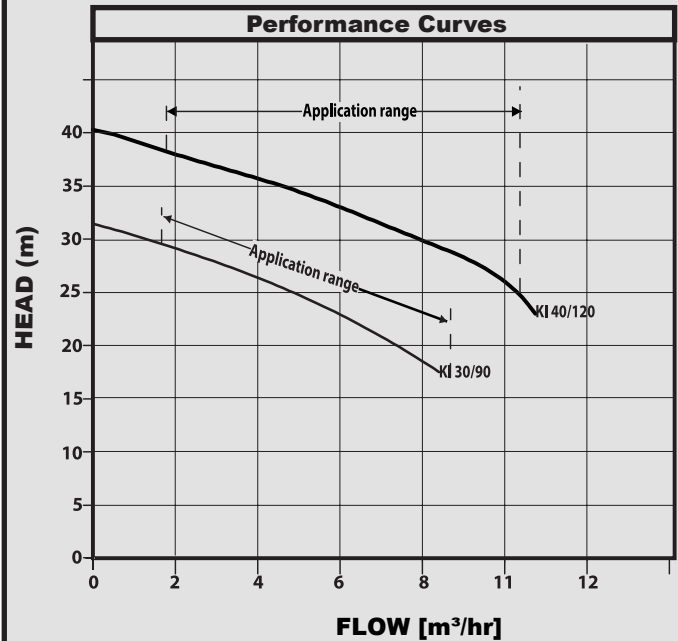

KI

HORIZONTAL CENTRIFUGAL PUMPS

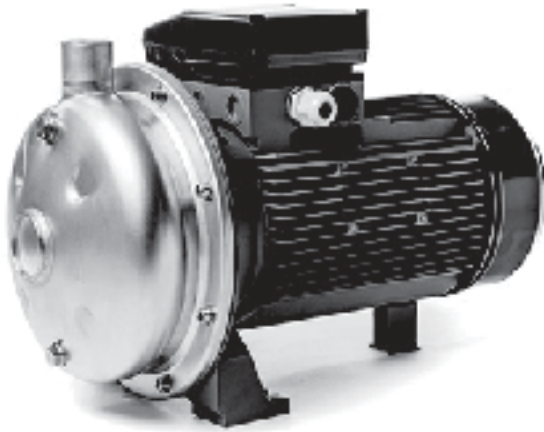

APPLICATIONS

KI Centrifugal pumps are ideal for boosting in domestic applications, fire hoses and water transfer.

CONSTRUCTION FEATURES

Axial suction AISI 304 stainless steel single impeller centrifugal pump, Induction motor, closed and cooled with external ventilation, built-in thermal & current overload protection.

Motor Protection: IP55

Terminal Box Protection: IP55

Insulation Class: F

Liquid Quality Requirements: Clean, free of solids or abrasive substances, non-viscous, non-aggressive, non-crystallized, chemically neutral, close to the characteristics of water.

Temperature: 0°C to 40°C

Maximum Suction Depth: 8 metres at sea level

Maximum Operating Pressure: 8 bar

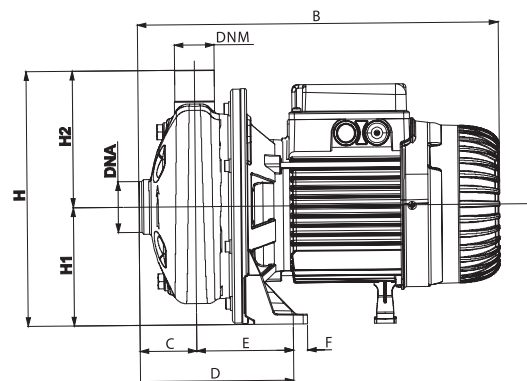
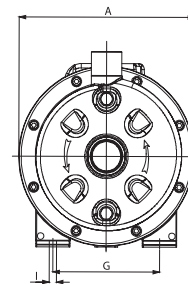

TECHNICAL DATA

Model	Motor Type	Power [kW]	HP	Amps	A	B	C	E	F	G	H	DNA	DNM	Weight KG
KI 30/90	240V	0.75	1	6.5	214	337	53	90.5	13	130	232	1 1/4" G	1"	13.3
KI 40/120		1.5	2	9.7	236	432		93.5		140	252			19.6