

APPLICATIONS

The GRUNDFOS CM pumps are designed to cover a wide variety of applications, ranging from small domestic installations to large industrial systems

CONSTRUCTION FEATURES

Compact design with pump and motor close coupled. Single phase motors are fitted with thermal overload protection. Axial suction and radial discharge ports. Front housing made of cast iron and impellers made of 304 stainless steel pump mounted on a base plate for ease of installation

Pump Liquids: Clean, thin, non-aggressive liquids without solid particles and fibre.

Liquid temperature: 0°C to 90°C

Max. Operating pressure: 10bar

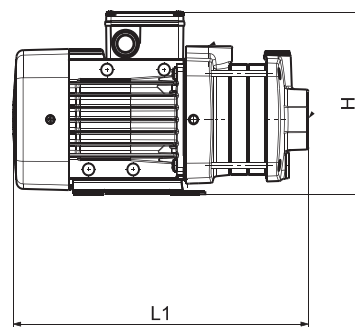
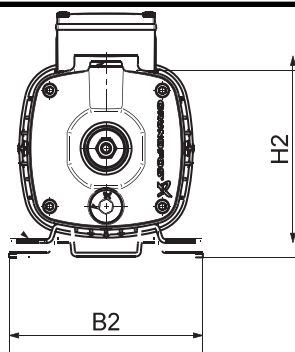
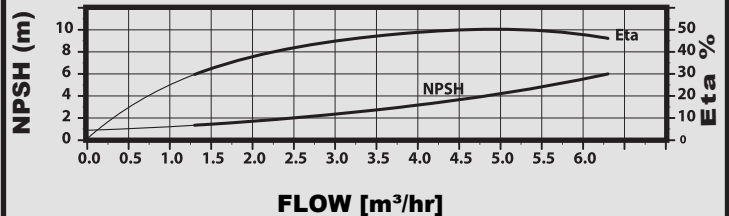
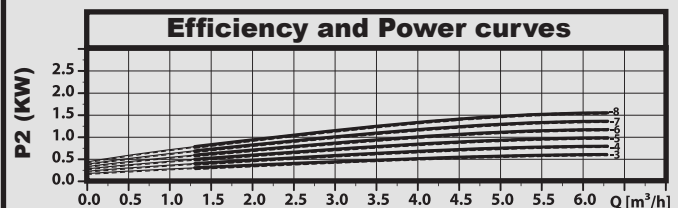
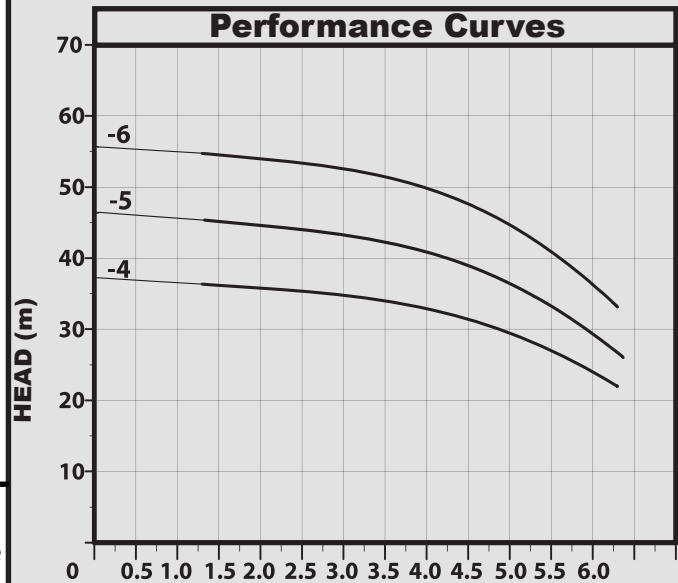

TECHNICAL DATA

Pump Type	1x240V kW	Operating Current	Start Current	Inlet	Outlet	DIMENSIONS(mm)			Weight (kg)
						B2	H2	L1	
CM5-4	0.7	4.2	16.4	1 1/4"	1"	158	149	364	16
CM5-5	0.9	5.2	22			158	149	382	18
CM5-6	1.3	8.9	30.3			158	201	451	26