

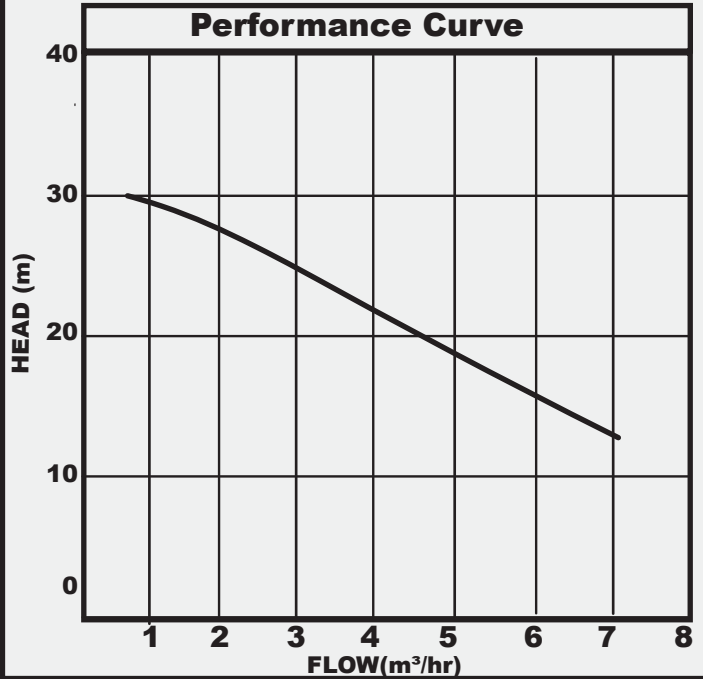

# AQUABOOST SINGLE

# CM32 BOOSTER PUMP



### APPLICATIONS

The **SPERONI CM32 BOOSTER** is a single impeller pump fixed with a TAFLO PRESS pressure control device with an option of a TAFLO pressure tank. It is designed for pressure boosting and water transfer

### CONSTRUCTION FEATURES

Cast Iron pump body and motor support, Technopolymer or castiron impeller and Carbon/Ceramic mechanical seal Induction motor, closed and cooled with external ventilation, built in thermal and current overload protection.

**Motor Protection:** IP44

**Terminal box Protection:** IP55

**Insulation Class:** F

**Liquid Quality:** Clean, free of solids or abbrasive substances, non-viscous, non-aggressive, non-crystaized, chemically neutral,close to the characteristics of water.

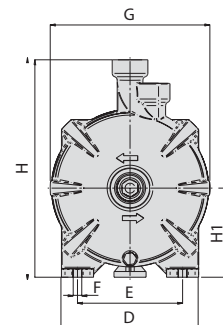
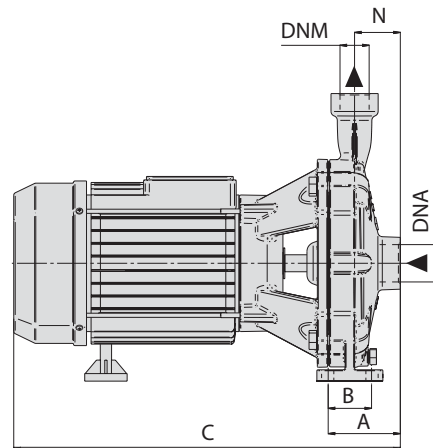

### TECHNICAL DATA

MODEL	POWER RATING			DIMENSIONS(MM)										INLET DNA	OUTLET DNM	WEIGHT KG	
	kW	HP	VOLTAGE	A	B	C	D	E	F	G	H	H1	N				
Type																	
CM32 BOOSTER	0.75	1	240	108	98	300	176	140	9	186	229	94	50	1"	1"	14.8	