

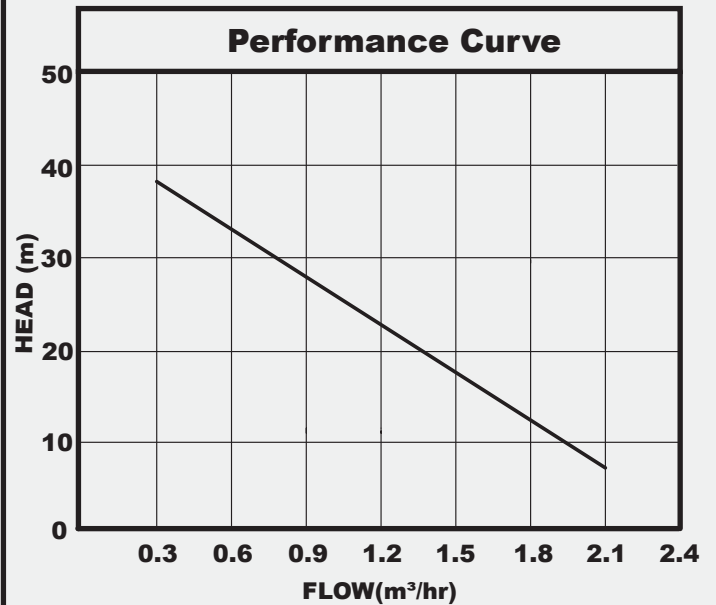

# AQUABOOST SINGLE

# KPM 50 BOOSTER PUMP



### APPLICATIONS

The SPERONI KPM50 BOOSTER is a peripheral impeller pump fixed with a TAFLO PRESS pressure control device with an option of a TAFLO pressure tank. It is designed for pressure boosting and water transfer.

### CONSTRUCTION FEATURES

Cast Iron pump body, brass impeller and carbon/ceramic mechanical seal, induction motor, closed and cooled with external ventilation, built-in thermal & current overload protection.

**Protection Rating:** IP44

**Terminal box Protection:** IP55

**Insulation Class:** F

**Liquid Quality:** Clean, free of solids or abrasive substances, non-viscous, non-aggressive, non-crystallized, chemically neutral, close to the characteristics of water.

**Temperature:** 0°C to 40°C

**Terminal box Protection:** 6 bar

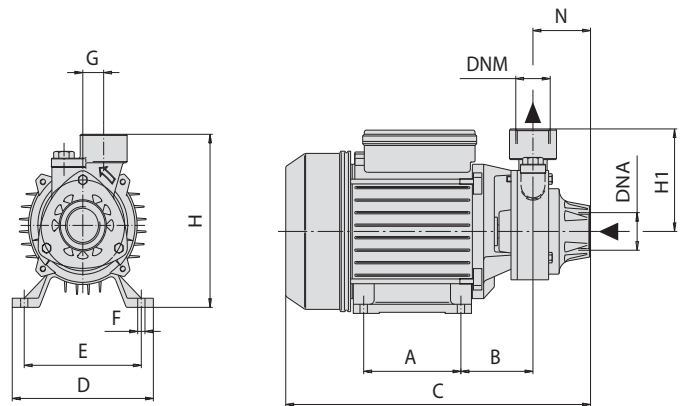

### TECHNICAL DATA

MODEL	POWER RATING			DIMENSIONS(MM)										INLET DNA	OUTLET DNM	WEIGHT KG
	Type	kW	HP	VOLTAGE	A	B	C	D	E	F	G	H	H1			
KPM 50 BOOSTER	0.37	0.5	240	80	65	255	120	100	7	20	144	81	50	1"	1"	6.1