

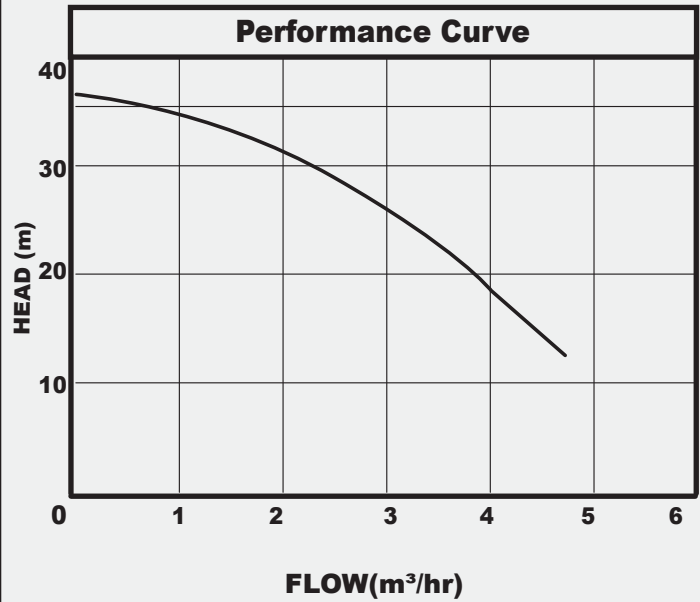

# AQUABOOST SINGLE

# RGXM3-4 BOOSTER PUMP



### APPLICATIONS

The **SPERONI RGXM3-4 BOOSTER** is a multistage centrifugal pump fixed with a TAFLO PRESS pressure control device with an option of a TAFLO pressure tank. It is designed for pressure boosting and water transfer

### CONSTRUCTION FEATURES

Compact design with pump and motor close coupled. single phase motors are fitted with thermal overload protection. Axial suction and radial discharge ports. Front housing made of cast iron and impellers made of 304 stainless steel pump mounted on a base plate for ease of installation.

**Pump liquids:** Clean, thin, non-aggressive liquids without solid particles and fibre.

**Liquid Temperature:** 0°C to 90°C

**Max Operating Pressure:** 5bar

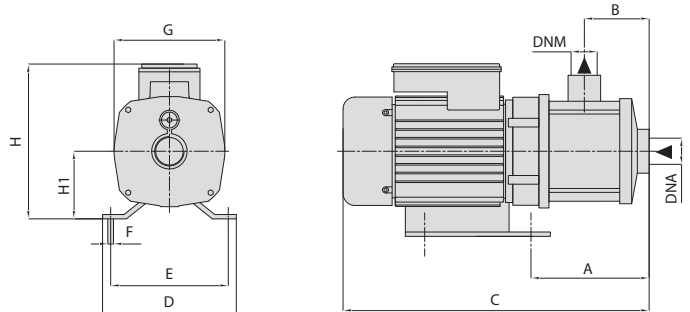

### TECHNICAL DATA

| MODEL            | POWER RATING |      |         | DIMENSIONS(MM) |    |     |     |     |    |     |     |    | INLET DNA | OUTLET DNM | WEIGHT KG |
|------------------|--------------|------|---------|----------------|----|-----|-----|-----|----|-----|-----|----|-----------|------------|-----------|
|                  | kW           | HP   | VOLTAGE | A              | B  | C   | D   | E   | F  | G   | H   | H1 |           |            |           |
| RGXM 3-4 BOOSTER | 0.55         | 0.75 | 240     | 149            | 90 | 365 | 158 | 125 | 11 | 140 | 187 | 75 | 1"        | 1"         | 9.4       |