

TAFLO

AQUABOOST SINGLE

CMI 3-4 BOOSTER PUMP

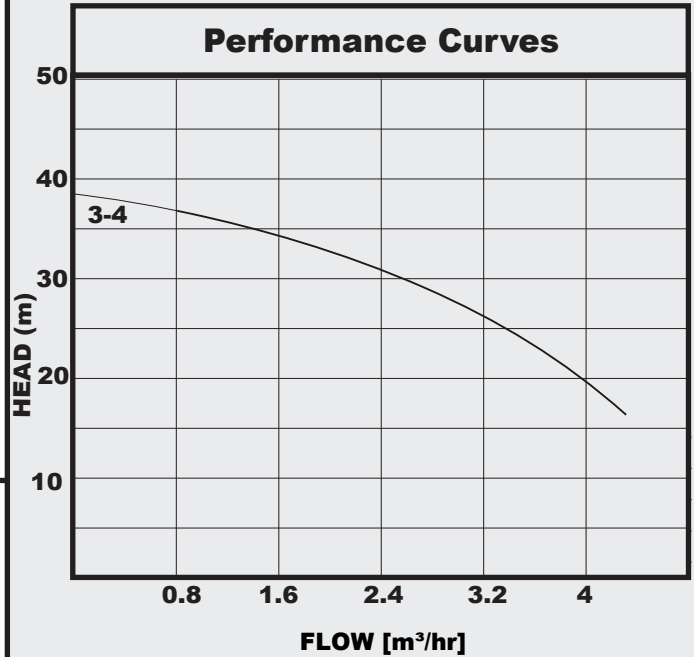

APPLICATIONS

The TAFLO CMI 3 BOOSTER is a horizontal design mul stage pump fi ed with a TAFLO PRESS pressure control device with an op on of a TAFLO pressure tank. It is designed for pressure boos ng and water transfer

CONSTRUCTION FEATURES

Robust cast iron suction and delivery housing, stain- less steel impellers, diffusers, wearings and pump casing coupled to asynchronous two pole air cooled squirel cage motor with inbuilt thermal overload protection. The pumps are designed for efficient and dependable performance and a long and trouble free life

PUMPED LIQUIDS: Clean, thin, non-aggressive liquids without solid particles

LIQUID TEMPERATURE: Maximum -20°C to +70°C

ENCLOSURE CLASS: IP54

INSULATION CLASS: F

RPM: 2850

TECHNICAL DATA

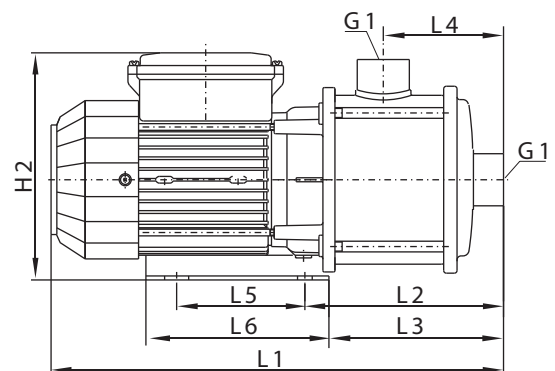
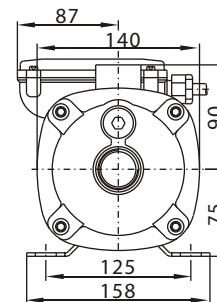

| MODEL | kW | VOLTAGE | DIMENSIONS | | | | | | | INLET | OUTLET | WEIGHT (KG) |
|----------------|------|--------------|------------|-----|-----|-----|----|----|-----|-------|--------|-------------|
| | | SINGLE PHASE | H2 | L1 | L2 | L3 | L4 | L5 | L6 | | | |
| CMI3-4 BOOSTER | 0.55 | 240 | 170 | 336 | 149 | 131 | 90 | 96 | 136 | G1" | G1" | 10 |