

TAFLO

E-BOOST SINGLE

VFB VARIABLE FREQUENCY PUMP



APPLICATIONS

The TAFLO E-BOOST VFB403 is a compact constant pressure booster pump designed to provide constant pressure in residential homes and is suitable for upto three storey buildings with five tapping points

CONSTRUCTION FEATURES

- Very silent operation with low noise level of $\leq 5\text{dB}$
- Pump housing made of ABS for durability and rust proof
- Interior pump body made of stainless steel SS304 which makes it strong and durable
- In-built pressure tank that eliminates cycling
- Mechanical seal made of silicon carbide and graphite
- Low standby power of upto 1W
- LCD display with intelligent controller
- In-built dry run protection
- In-built VFD
- In-built non return valve
- Adjustable constant pressure

Max. Ambient Temperature: 40°C

Liquid Temperature: $0^{\circ}\text{C} - 100^{\circ}\text{C}$

Protection Rating: IP54

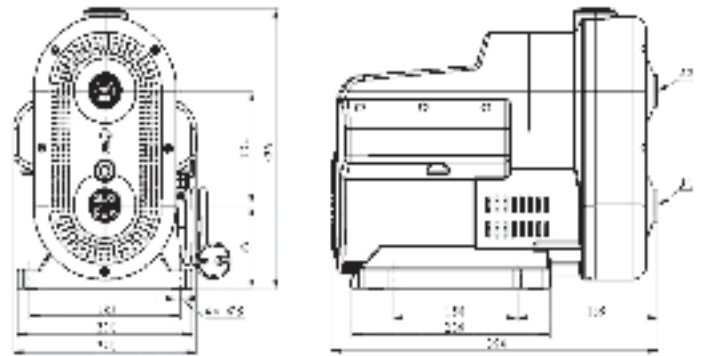
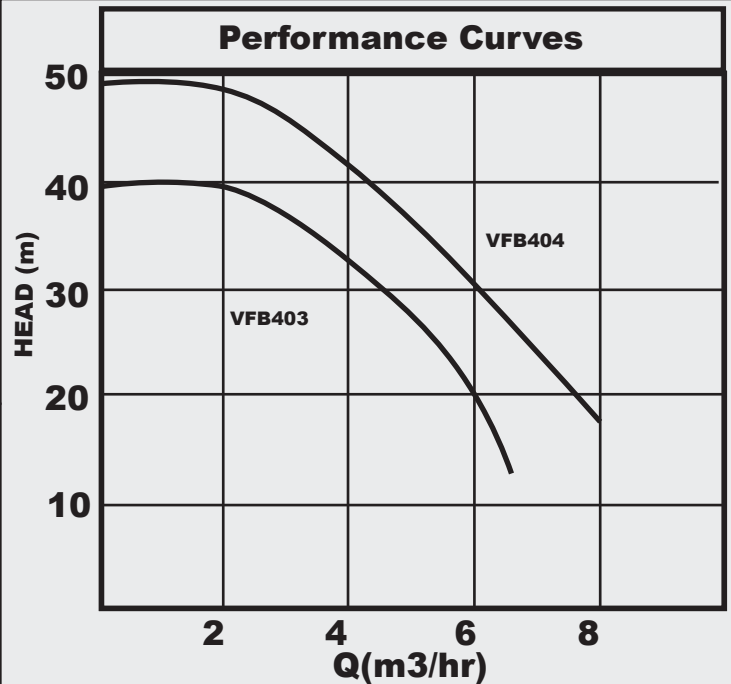

TECHNICAL DATA

| MODEL | VOLTAGE (V) | POWER (kW) | HEAD (m) | FLOW RATE M3/hr | | | | INLET | OUTLET | NET WEIGHT (Kg) |
|----------------------|-------------|------------|----------|-----------------|-----|-----|-----|--------|--------|-----------------|
| | | | | 10 | 20 | 30 | 40 | | | |
| TAFLO E-BOOST VFB403 | 220 | 0.75 | - | - | 6 | 4.5 | 2 | G1.25" | G1" | 13.1 |
| TAFLO E-BOOST VFB404 | 220 | 1.1 | | - | 7.2 | 6 | 4.2 | G1.25" | G1" | 15.6 |