

TAFLO

E-BOOST SINGLE

VFG VARIABLE FREQUENCY PUMP



APPLICATIONS

The TAFLO E-BOOST VFG403 is a compact constant pressure booster pump designed to provide constant pressure in residential homes and commercial buildings

CONSTRUCTION FEATURES

- Very silent operation with low noise level
- Fitted with a variable frequency drive(VFD) with LCD display for ease of operation
- In-built dry run protection
- In-built non return valve
- Adjustable constant pressure
- Multiple pumps can be connected together
- Fitted with pressure tank that eliminates cycling

Max. Ambient Temperature: 40°C

Liquid Temperature: 0°C - 100°C

Protection Rating: IP54

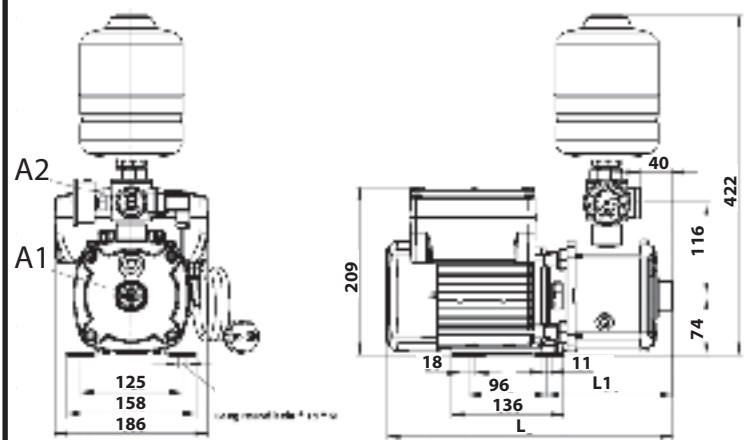
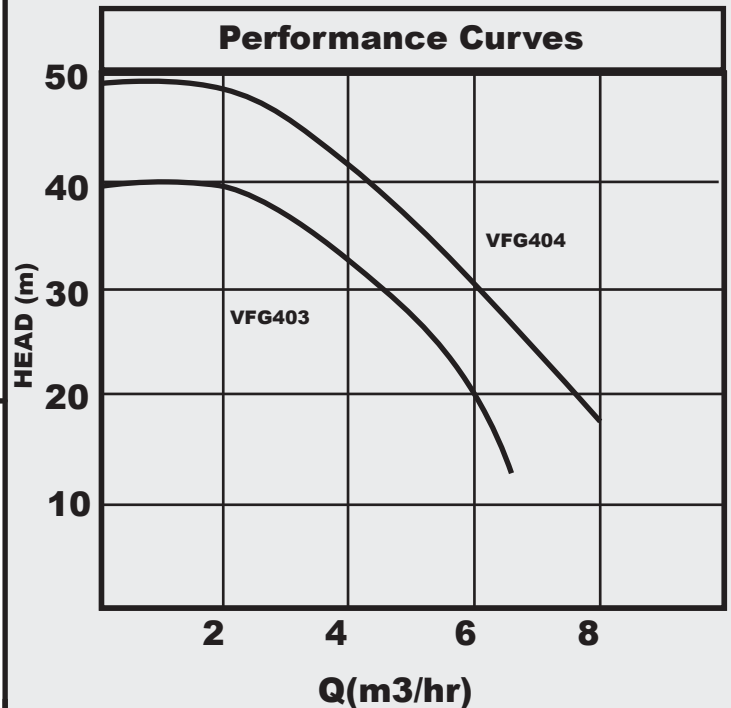

TECHNICAL DATA

MODEL	VOLTAGE (V)	POWER (kW)	HEAD (m)	10	20	30	40	INLET	OUTLET	NET WEIGHT (Kg)
				FLOW RATE M3/hr						
TAFLO E-BOOST VFG403	220	0.75	FLOW RATE M3/hr	-	6	4.5	2	G1.25"	G1"	13.9
TAFLO E-BOOST VFG404	220	1.1		-	7.2	6	4.2	G1.25"	G1"	13.9