

APPLICATIONS

The Vansan VSS pumps are designed for borehole installations as well as lifting, distribution and pressurization applications.

CONSTRUCTION FEATURES

Diffusers, Impellers, Brackets, Suction case and Discharge case completely made of stainless steel AISI 304 in order to provide maximum strength, durability, wear and tear resistance.

Max. Permissible Sand/silt: 50g/m³

Max. Ambient Temperature: 30°C

Installation: Vertical/Horizontal.

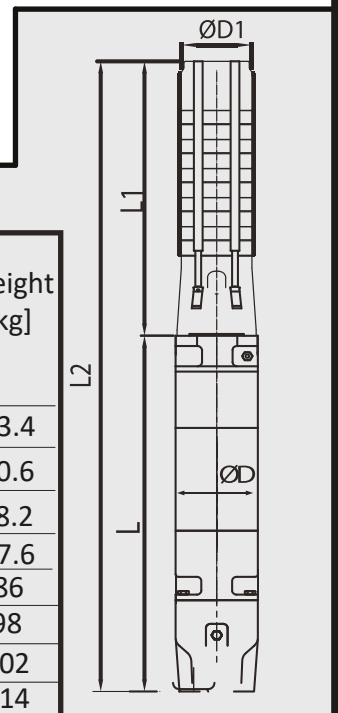

TECHNICAL DATA

Model	Motor Type	Electrical Data			L2 [mm]	L [mm]	L1 [mm]	D [mm]	D1 [mm]	Outlet	Weight [kg]
		P2 Nominal		In A							
		[kW]	[HP]								
VSS17-07	6GF	4	5.5	10.2	1293	600	693	141	132	2 1/2"	53.4
VSS17-10	6GF	5.5	7.5	13.7	1505	631	874				60.6
VSS17-13	6GF	7.5	10	17.2	1716	660	1056				68.2
VSS17-17	6GF	9.3	12.5	20.8	1983	685	1298				77.6
VSS17-20	6GF	11	15	23.7	2209	730	1479				86
VSS17-24	6GF	15	20	28.7	2506	785	1721				98
VSS17-27	6GF	15	20	33.1	2688	785	1903				102
VSS17-30	6GF	18.5	25	41.8	2944	860	2084				114