

# TAFLO

**CRANE QX**

**CONSTRUCTION PUMP**



## Performance Curves

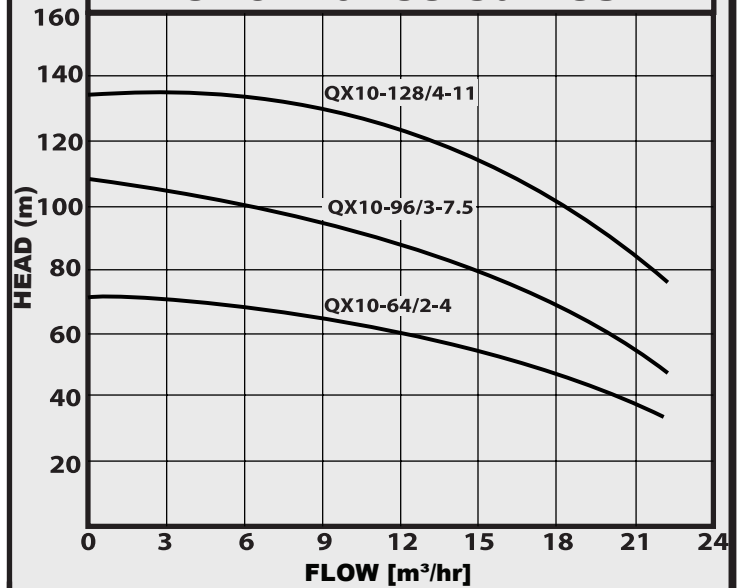

### APPLICATIONS

The Crane QX Submersible pumps are multistage high head pumps designed for dewatering in mines, construction sites and also suitable for irrigation and water transfer applications.

### CONSTRUCTION FEATURES

- Compact design makes it easy to install
- Heavy duty design to handle slurry and muddy water
- Fitted with lifting hooks for ease of installation

**Pumped liquid:** Slurry and muddy water containing sand

**Temp:** 0°C to 35°C

**Max. operating pressure:** 14 bar

**Max. Immersion depth:** 12 m

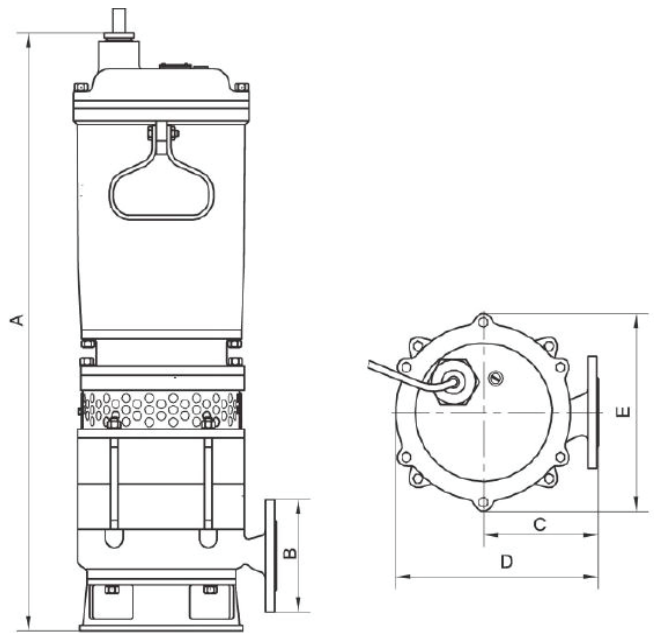

### TECHNICAL DATA

MODEL	VOLTAGE	kW	HP	Dimensions (mm)					Outlet	WEIGHT KG
				A	B	C	D	E		
QX10-64/2-4	415V	4	5.5	690	Φ150	155	270	275	2"	75
QX10-96/3-7.5		7.5	10	800		155	270		2"	100
QX10-128/4-11		11	15	1200		160	275		2"	140