

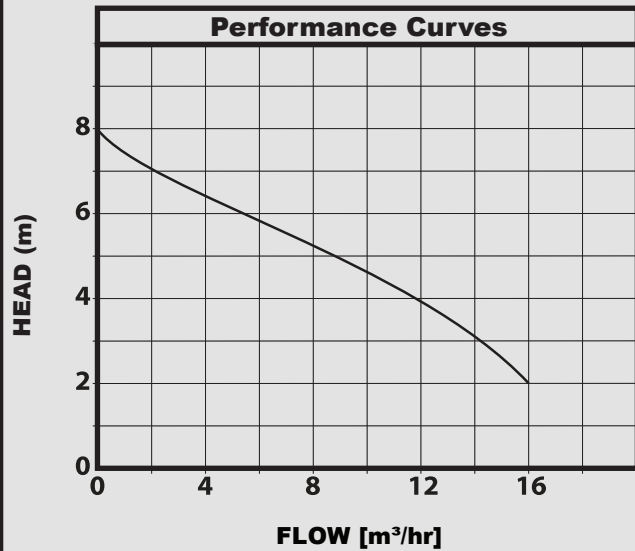

FEKA600

SEWAGE PUMPS



APPLICATIONS

The DAB FEKA are suitable for pumping sewage and waste water containing solids

CONSTRUCTION FEATURES

Anti-corrosion and anti-oxidant materials. Motor with thermal protection against overheating. Wear resistant motor shaft and impeller.

Excellent motor cooling to allow pump to run even when only partially submerged

Fitted with float switch for automatic starting and stopping of the pump.

Motor protection: IP68

Insulation class: F

Liquid quality requirements: 0°C to +35°C

Liquid temp. range: 0°C to +35°C

Max. immersion depth: 20meters

Installation: IP68

Free passage: 25mm

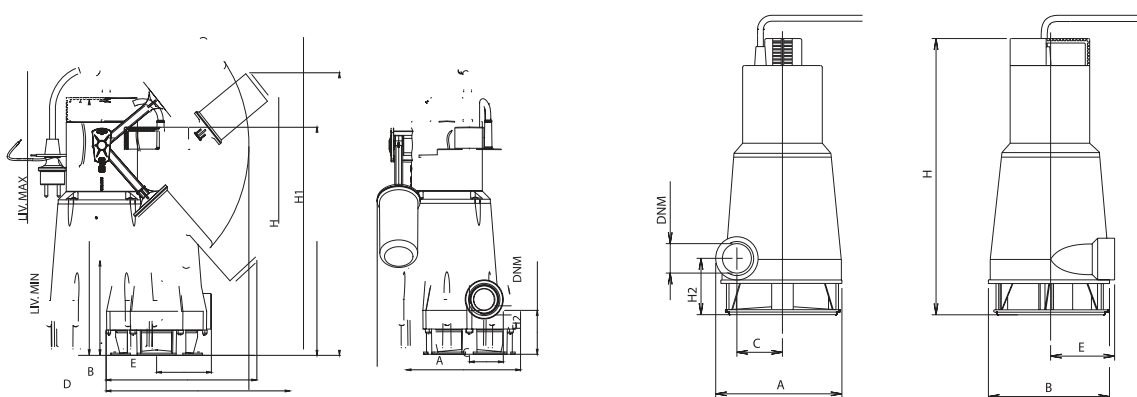

TECHNICAL DATA

| MODEL | VOLTAGE 50Hz | kW | HP | Amps | A | B | C | D | E | H | H1 | H2 | DNM | WEIGHT KG |
|-------------|--------------|------|------|------|-----|-----|----|-----|----|-----|-----|----|--------|-----------|
| FEKA600 M-A | 240V | 0.55 | 0.75 | 4.3 | 193 | 235 | 56 | 296 | 90 | 368 | 443 | 73 | 1 1/4" | 7 |