

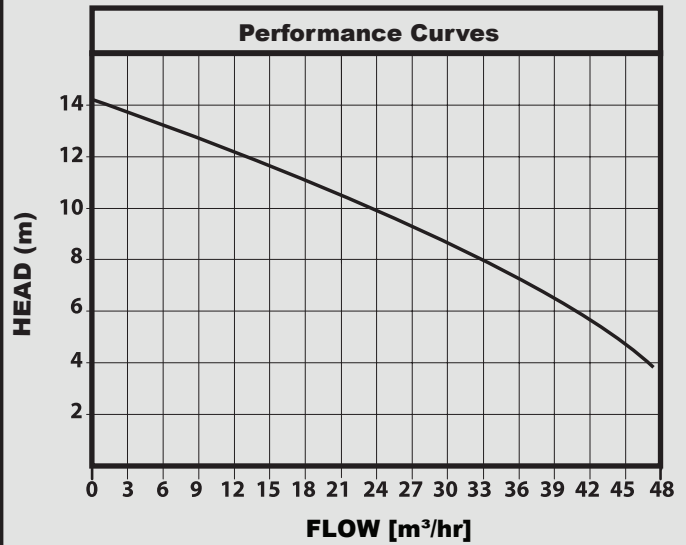

# FEKA 2500

# SEWAGE PUMP



### APPLICATIONS

Cast iron submersible pump with vortex impeller suitable for sewage and waste water with solid particles up to 42 mm diameter.

### CONSTRUCTION FEATURES

Motor body and hydraulic section in cast iron EN GJL200. Double mechanical seal in oil chamber motor side carbon/alumina, pump side in silicon carbide. Dry type asynchronous sealed motor. Rotr mounted on ball bearings to ensure silent running and long life.

**Motor protection rating:** IP68

**Insulation class:** F

**Liquid temp. range:** 0° to 40°C

**Max. immersion dpth:** 20meters

**Installation:** Vertical position

**Free passage:** 62mm

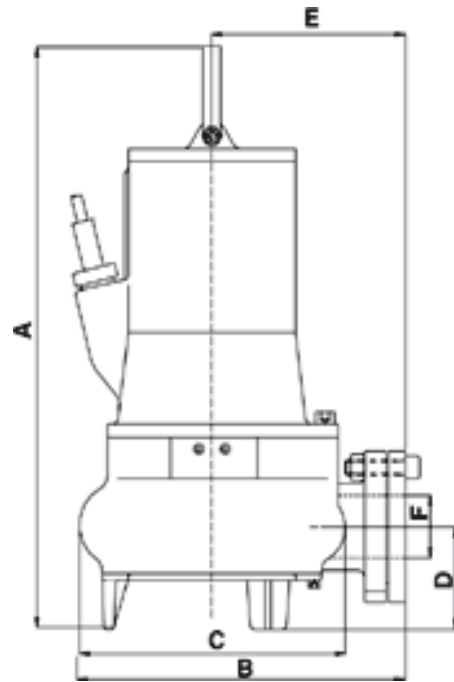

### TECHNICAL DATA

MODEL	ELECTRICAL DATA					A	B	C	D	E	F Ø	DNM	FREE PASSAGE mm	WEIGHT KG
	VOLTAGE	P1 MAX kW	P2 NORMAL kW HP		In A									
FEKA 2500.2T	3 x 400V~	2.8	1.8	2.4	4.7	515	260	217	90	145	62	2 1/2"	62	70