

TAFLO

NISO

END-SUCTION PUMPS

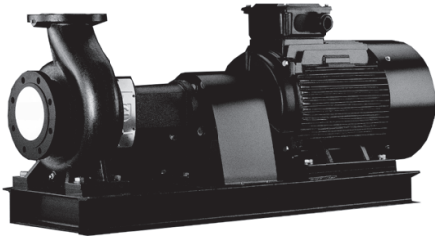

Performance Curves

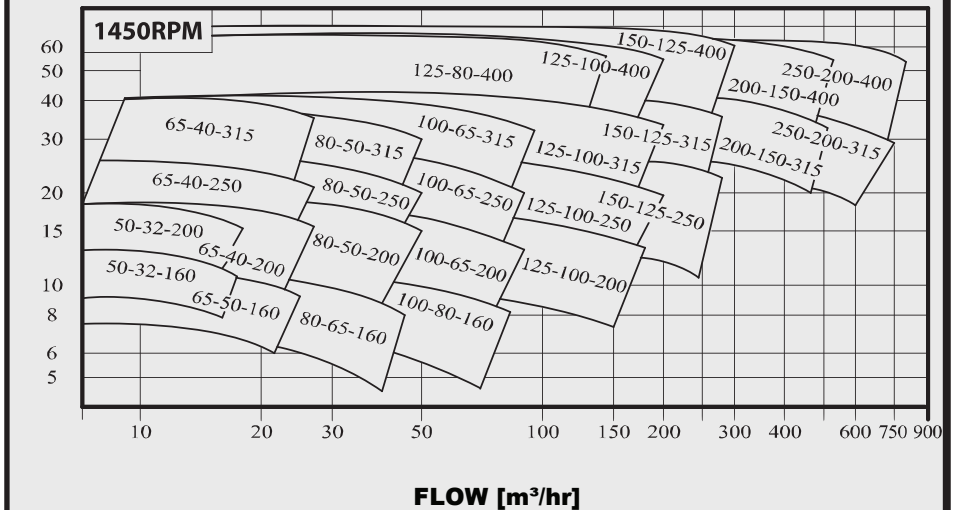
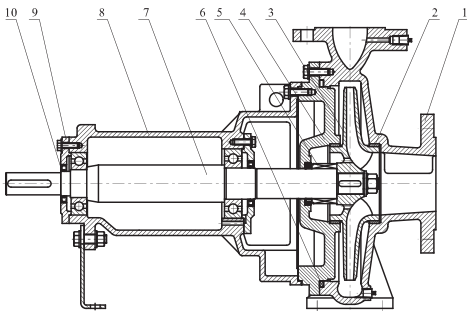
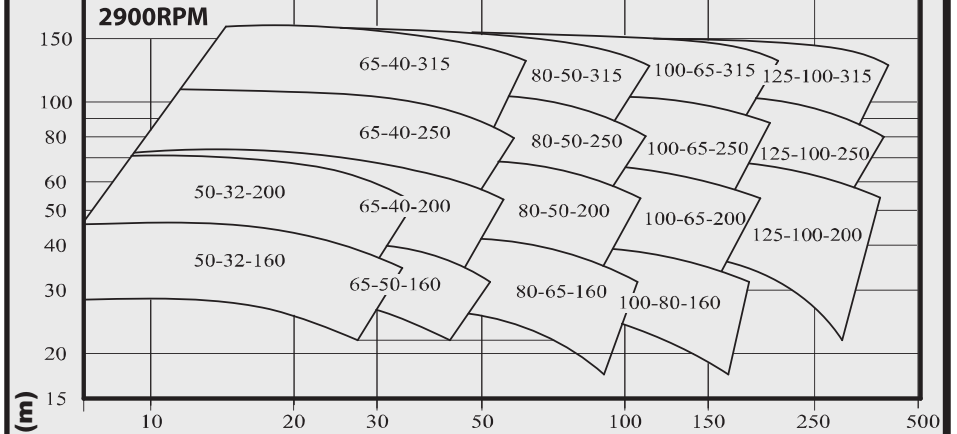

PARTS LIST

No.	Name	Material	Code/AISI/ASTM
1	Casing	Cast Iron HT200	ASTM25B
2	Wear ring	Cast Iron HT200	ASTM25B
3	Impeller	Cast Iron HT200/SS 304	ASTM25B/AISI304
4	Casing cover	Cast Iron HT200	ASTM25B
5	Mechanical seal	Carbon/Silicon Carbide	
6	O ring	NBR	
7	Shaft	SS 20Cr13	AISI420
8	Bearing housing	Cast Iron HT200	ASTM25B
9	Bearing cover	Cast Iron HT200	ASTM25B
10	Oil seal	NBR	