

# TAFLO

## WQB

## DRAINAGE PUMP



### Performance Curves

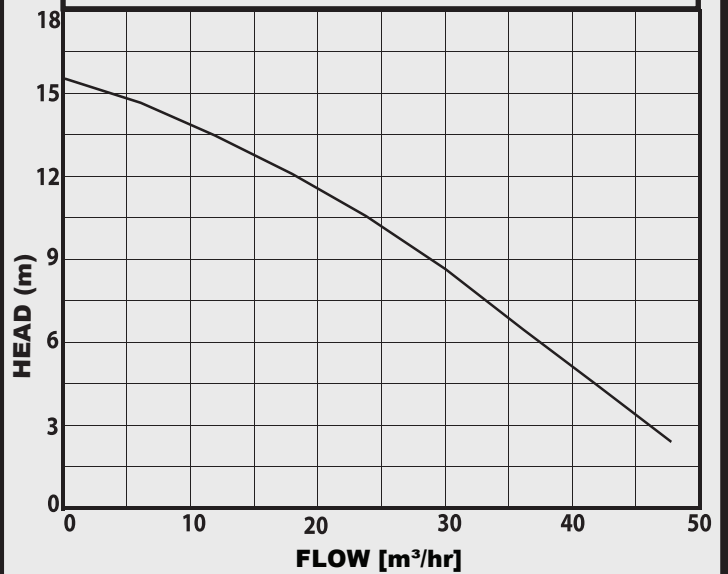

### APPLICATIONS

The TAFLO WQB drainage pump is designed for draining, lifting or transfer of clear waste water with maximum diameter of 50mm

### CONSTRUCTION FEATURES

- Vortex Impeller made of stainless steel AISI304
- Anti-corrosion and rust-proof stainless steel pump body
- Fitted with float switch for automatic level control
- Built in thermal overload relay
- Supplied with 10m H07RN-F Submersible cable.

**Pumped liquid:** Waste water containing particles upto 50mm

**Temp:** 0°C to 40°C

**Max. operating pressure:** 1.6 bar

**Max. Immersion depth:** 7 m

**Insulation:** B class, IP68 Protection

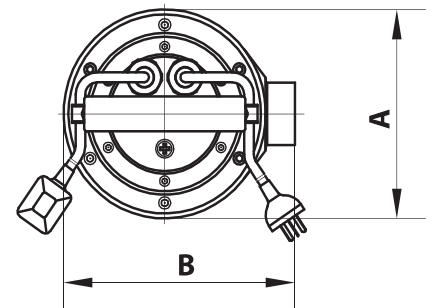
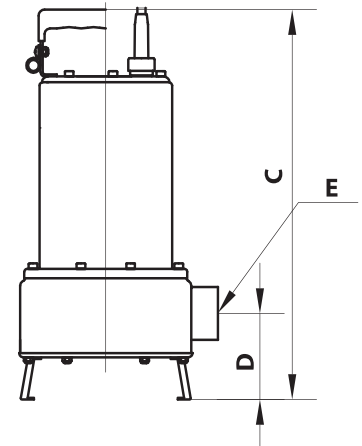

### TECHNICAL DATA

MODEL	VOLTAGE	kW	HP	Dimensions (mm)					WEIGHT KG
				A	B	C	D	Outlet	
WQB	415V	2.2	3	190	225	470	110	3"	21