

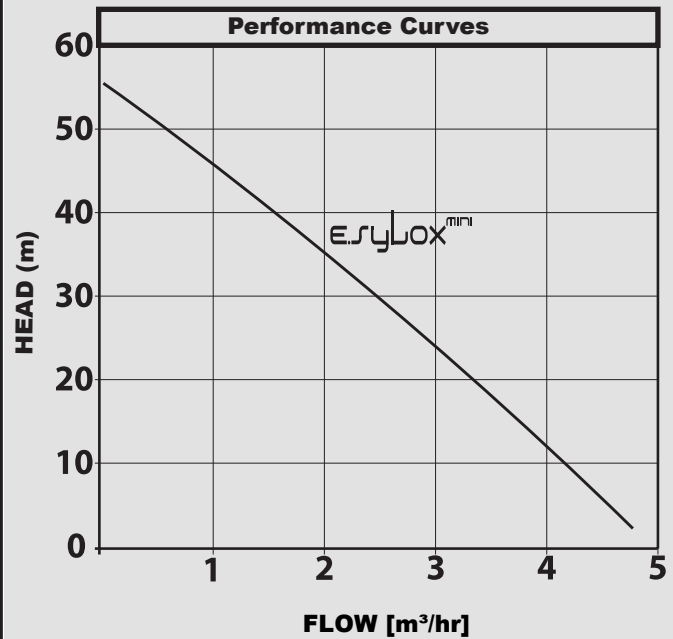

E.SYBOX^{mini}

CONSTANT PRESSURE BOOSTER PUMP



APPLICATIONS & CONSTRUCTION FEATURES

E.SYBOX is DAB’s new intergrated compact VARIABLE SPEED pressure booster system suitable for pressure boosting and hose reel applications. It does not require any additional components for installation. It consists of a self priming multi-stage pump, electronic variable speed inverter, flow and pressure sensors, high resolution swivel LCD display and an intergrated two litre expansion tank. It can be installed both vertically and horizontally and even in tight spaces where ventillation is limited.

Degree of Protection: IPX4.

Insulation class: F. **Pumped liquid:** Clean, free from solids, non-agressive, non-viscous, non-crystalized and chemically neutral.

Min. liquid temperature: 40°C. **Max. Ambient Temp.:** 50C. **Max. Suction depth:** 8meters.

Max. working pressure: 8bar

DESIGN FEATURES INCLUDE:

- Water cooled motor and sound dampening casing creating the quietest booster pump available today at 45dB
- Energy efficient variable speed motor operating from 0.3kW to 1.5kW
- Powerful performance with flow up to 4.5m³/h and head up to 5.5bar
- Self priming down to 8m
- Dry running protection
- Anti-vibration mountings
- Flexible installation with horizontal or vertical position
- Intergrated chamber with expansion vessel, tool kit and installer manual

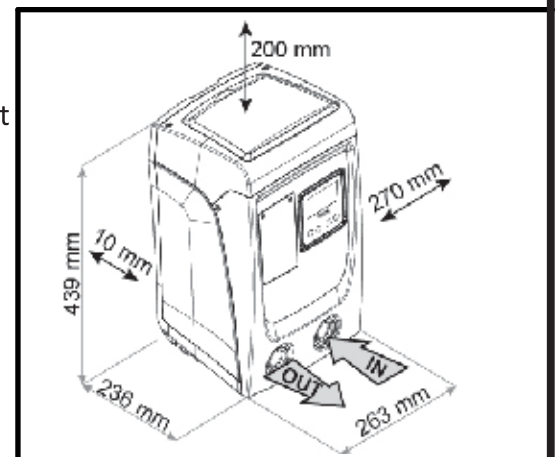

TECHNICAL DATA

Model	ELECTRICAL DATA				DIMENSIONS (mm)			DNA GAS	DNM GAS	Weight KG
	Voltage 50Hz	Power [kW]	HP	I _{max}	L	W	H			
E.SYBOX MINI	240v~	0.8	1.07	8	263	236	439	1"		14