

TAFLO

PPB50

POOL PUMPS

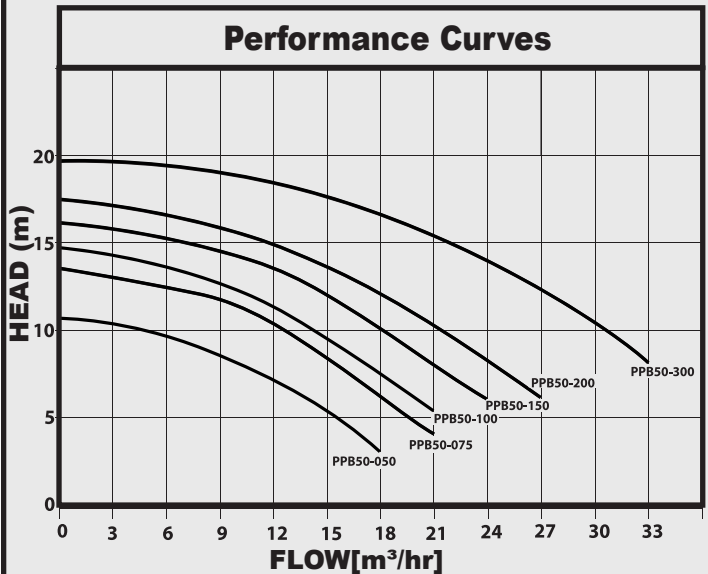

APPLICATIONS

Quiet running centrifugal pumps designed for water circulation and filtration in domestic and commercial swimming pools.

CONSTRUCTION FEATURES

Pump body and impeller in thermoplastic, strainer cover in clear antioxidant polycarbonated and fitted with a Nylon strainer. Asynchronous continuous duty motor housed in die cast aluminium casing.

Motor and terminal box protection rating: IP55

Insulation class:F

Pumped fluid: clean water or water slightly contaminated with suspended particles, long fibre; highly aggressive water with high percentage contents of chlorine

Temp range: up to 60°C

Max Operating pressure: 2bar

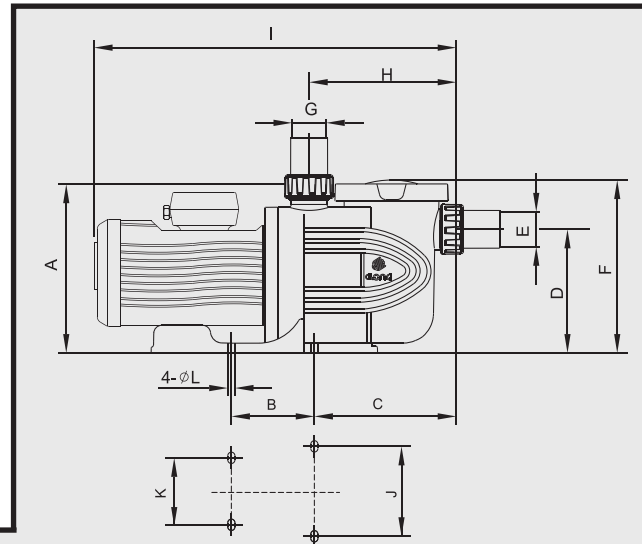

TECHNICAL DATA

Model	HP	kW	V	Amps	A	B	C	D	E & G	F	H	I	J	K	L	WEIGHT KG
PPB50-050	0.50	0.37	220	3.1	266	134	229	195	∅ 63∅	273	238	595	190	154	11.5	12.5
PPB50-075	0.75	0.55		4.2	266	134	229	195	∅ 63∅	273	238	595	190	154	11.5	13.5
PPB50-100	1.0	0.75		5.3	266	134	229	195	∅ 63∅	273	238	605	190	154	11.5	14.5
PPB50-150	1.5	1.1		7.2	266	134	229	195	∅ 63∅	273	238	605	190	154	11.5	15.5
PPB50-200	2	1.5		9.4	266	134	229	195	∅ 63∅	273	238	640	190	154	11.5	18
PPB50-300	3	2.2		13.0	266	134	229	195	∅ 63∅	273	238	640	190	154	11.5	20.5