



UPA BOOSTER 15-90



UPA BOOSTER 120

APPLICATIONS

The Grundfos UPA range circulator pump designed for pressure boosting of portable water and provides additional pressure to showers, taps and similar outlet points for domestic water. They are designed for use in open systems. The pump incorporates a flow switch which starts or stops the pump when a tap is turned on or off making it the ideal solution for domestic water boosting.

FEATURES

Adds between 0.5bar and 1.2bar pressure to the existing inlet pressure

- Stainless steel encapsulated rotor
- Stainless steel rotor can and bearing plate.
- Pump can be set to “MANUAL”, “AUTO” or “OFF”.
- Flow rates up to 3m³/h.
- Silent operation

TECHNICAL DATA

Model	Power (watts)	Full load Current (Amps)	Weight kg Net
UPA15-90	118	0.48	2.5
UPA120	250	1.14	5

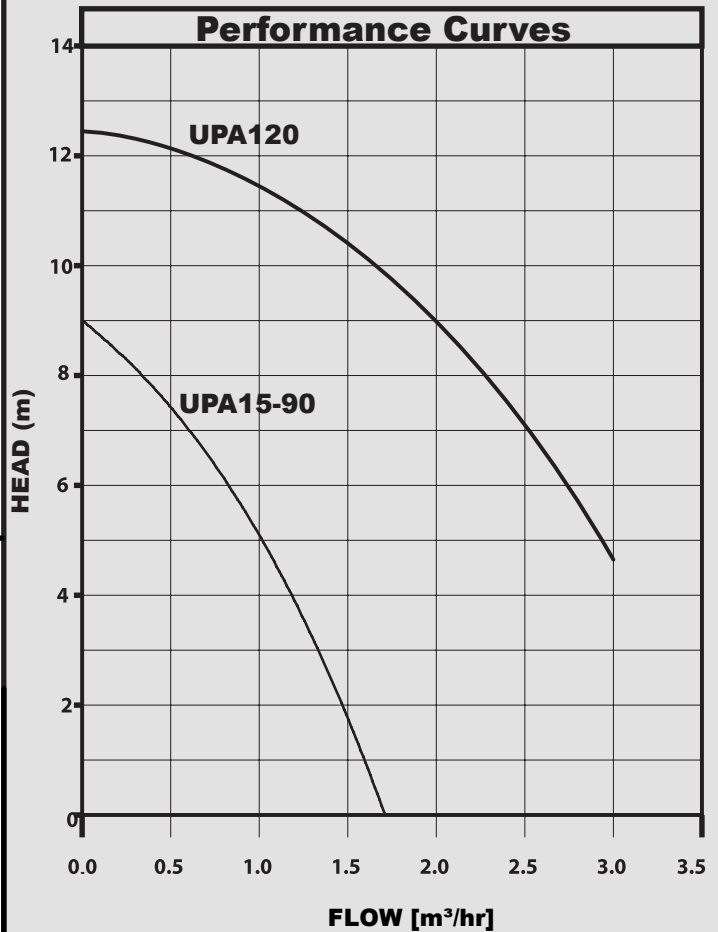

UPA BOOSTER 15_90

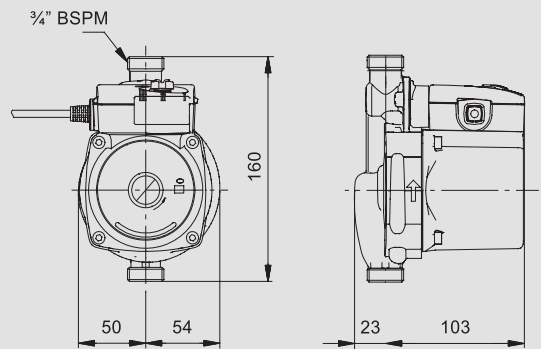

UPA BOOSTER 120

