

TAFLO

VSM

SEWAGE PUMPS

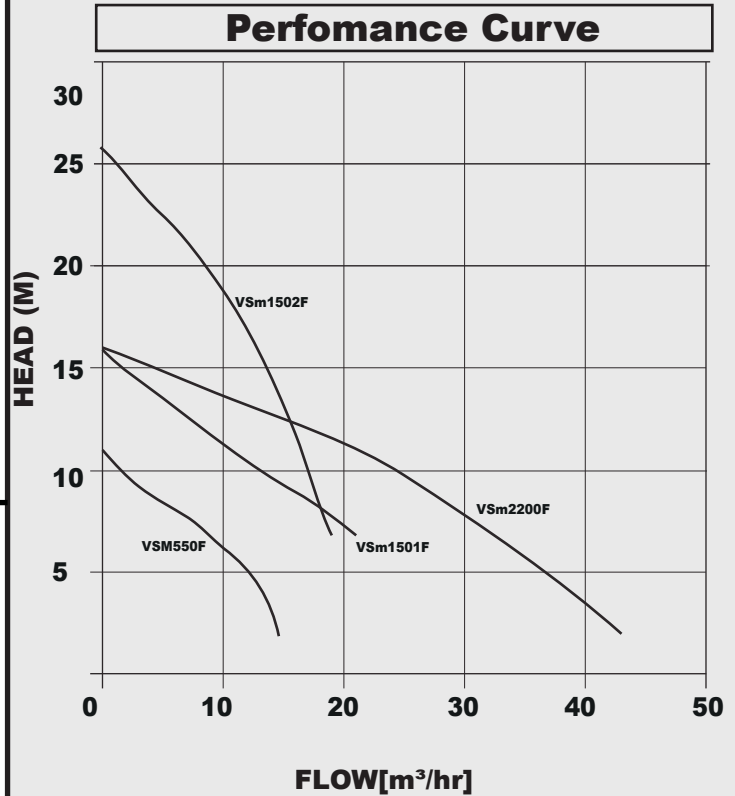

APPLICATIONS

The TAFLO VSM range are submersible pumps designed for pumping sewage and waste water containing solids of upto 50mm.

CONSTRUCTION FEATURES

- Unshrouded open impeller for free passage of particles
- Designed for continuous duty
- Fitted with float switch for automatic level control
- Built in thermal overload relay
- Fitted with 8m cable.

Pumped liquid: Sewage and waste water containing particles upto 50mm

Temp: 0°C to 40°C

Max. operating pressure: 2.5 bar

Max. Immersion depth: 10 m

Insulation: B class, IP68 Protection

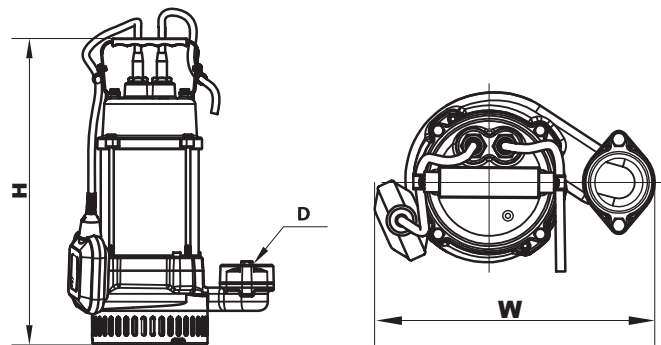

TECHNICAL DATA

MODEL	VOLTAGE	kW	HP	DIMENSIONS(mm)		Outlet	WEIGHT (kg)
				H	W		
VSM 550(F)	240	0.55	0.75	435	240	2"	17
VSM 1501F	240	1.5	2	522	240	2"	25
VSM 1502F	240	1.5	2	499	240	2"	28
VSM 2200(F)	415	2.2	3	521	240	3"	37